

PACKAGING TAPE NANO-TTI

Self-reading, idiot proof and accurate TTIs that monitor and inform store managers the quality of foods without opening a box of perishables

**A NEW AND MORE PRACTICAL CLASS
OF TIME-TEMPERATURE INDICATORS**

**IF TTIs MONITORS
SHELF-LIFE OF
PERISHABLES,
WHY ARE THEY NOT
WIDELY USED ON
FOOD PACKAGES?**

TTI ON INDIVIDUAL UNITS

Perishable manufacturers are not willing to use TTI labels on individual units of perishables (except vaccines, fresh blood,...etc) because:

- Special equipment and enormous quantity of properly sized TTI stickers are required

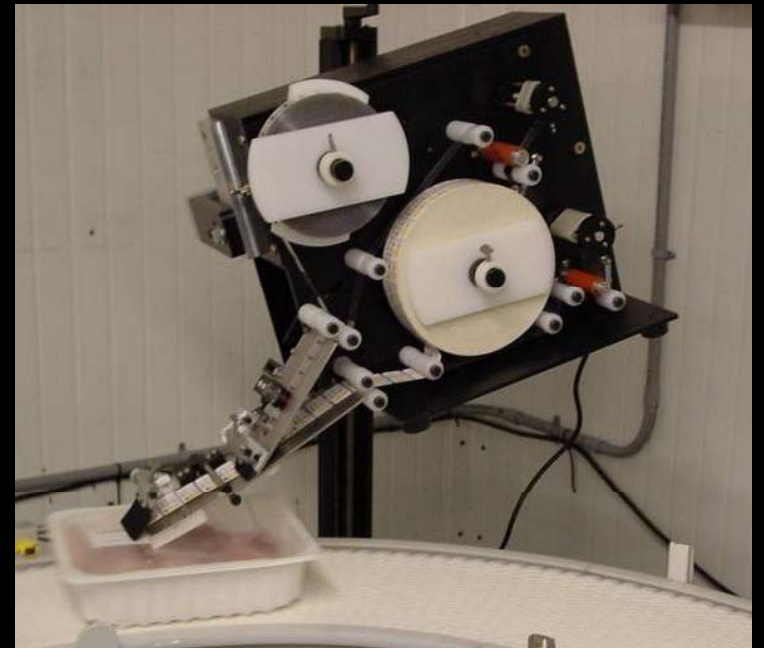

TTI ON INDIVIDUAL UNITS

Perishable manufacturers are not willing to use TTI labels on individual units of perishables (except vaccines, fresh blood,...etc) because:

- Special equipment and enormous quantity of properly sized TTI stickers are required
- Loss of individual TTI labels, tampering and liability are concerns
- Cost of TTI labels and their application is high
- Consumers are not educated/trained to interpret the TTI
- Returned and rejected product are concerns
- **Self reading & Go/No-go type TTI were not available**

TTI PACKAGING TAPE

**A NEW AND MORE
PRACTICAL APPROACH**

A NEW CLASS OF TTI

- Perishable manufacturers would like to use a TTI on carton/box of perishables but the current TTI are too small to be noticed on large boxes and for many other reasons described earlier

It is hard to notice a TTI even on this small unit

Comparez le
Prix d'achat et de vente

ooshop.com
Le cybermarché de Carrefour

EXCLUSIVITÉ sur le net

FRAICHEUR MAINTENUE
jusqu'à chez vous...
constatez-le à réception

mandar

Produit et distribué

A NEW CLASS OF TTI

- Perishable manufacturers would like to use a TTI on carton/box of perishables but the current TTI are too small to be noticed on large boxes
- Boxes are typically sealed with a tape
- **If the tape itself is a TTI, perishable manufactures/distributors are highly likely to use TTI on each box**

A NEW CLASS OF TTI

- A tape dispenser for dispensing an activated Nano sealing/packaging tape TTI

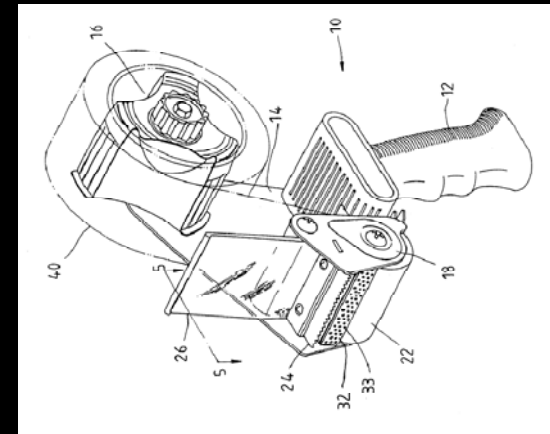
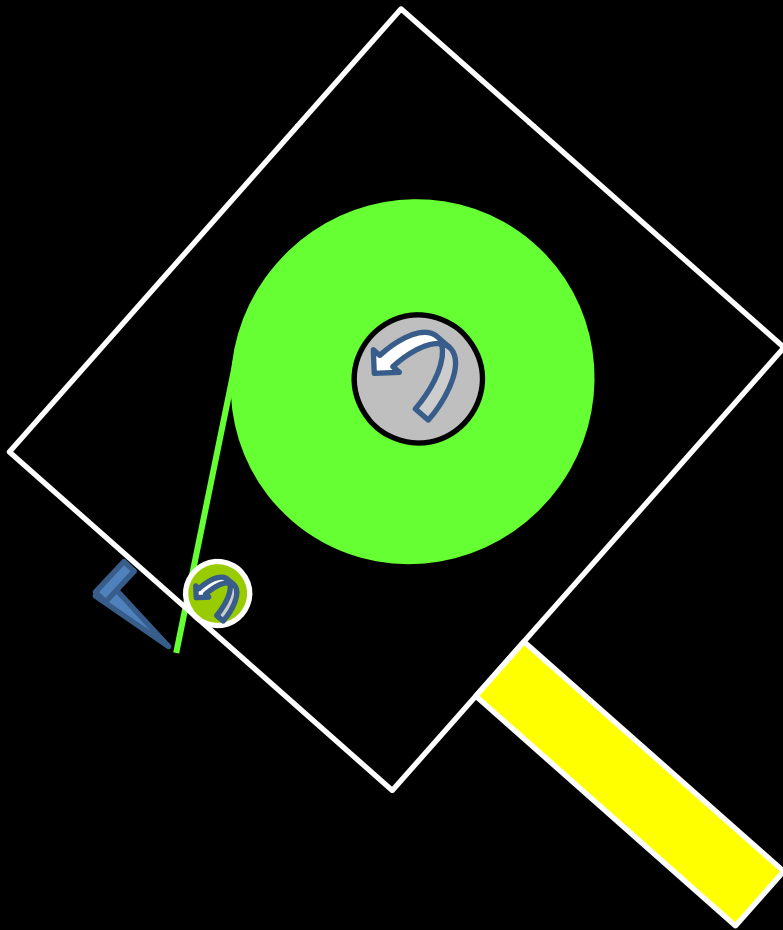

A NEW CLASS OF TTI

A closed box containing
number of perishables
for shipment

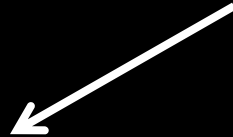
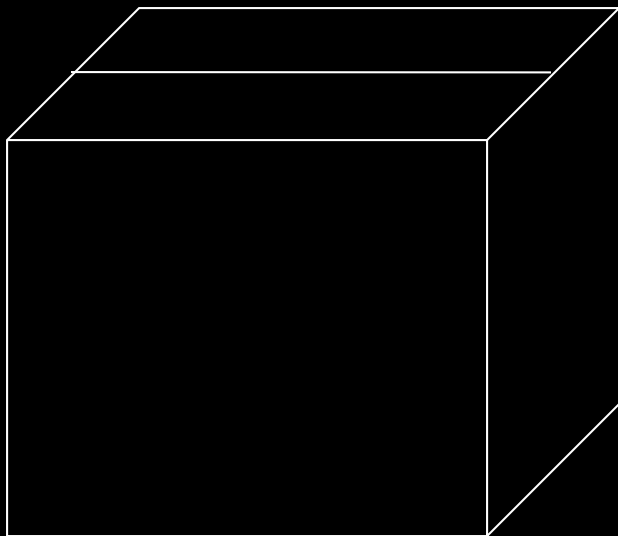

A NEW CLASS OF TTI

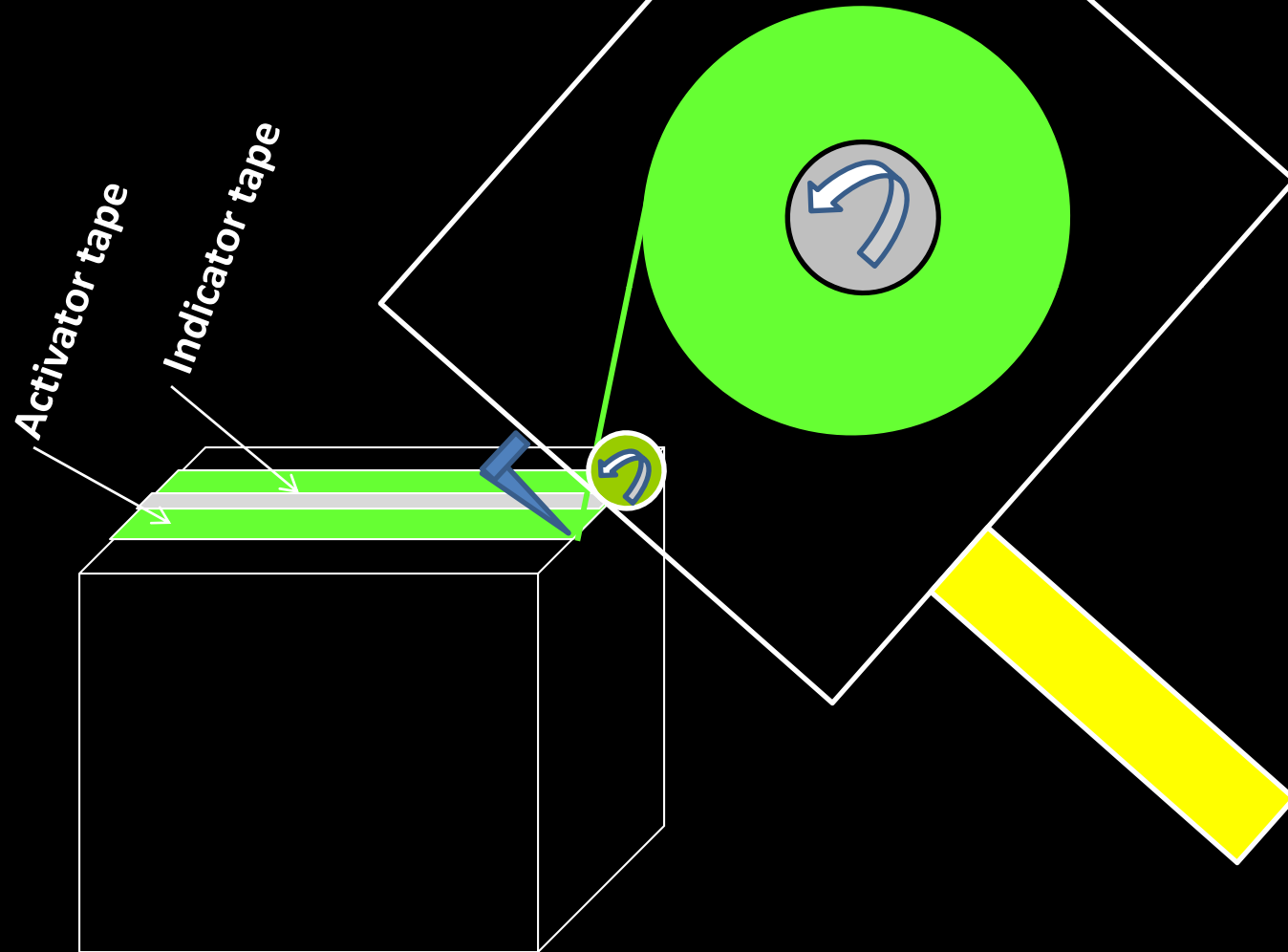

A NEW CLASS OF TTI

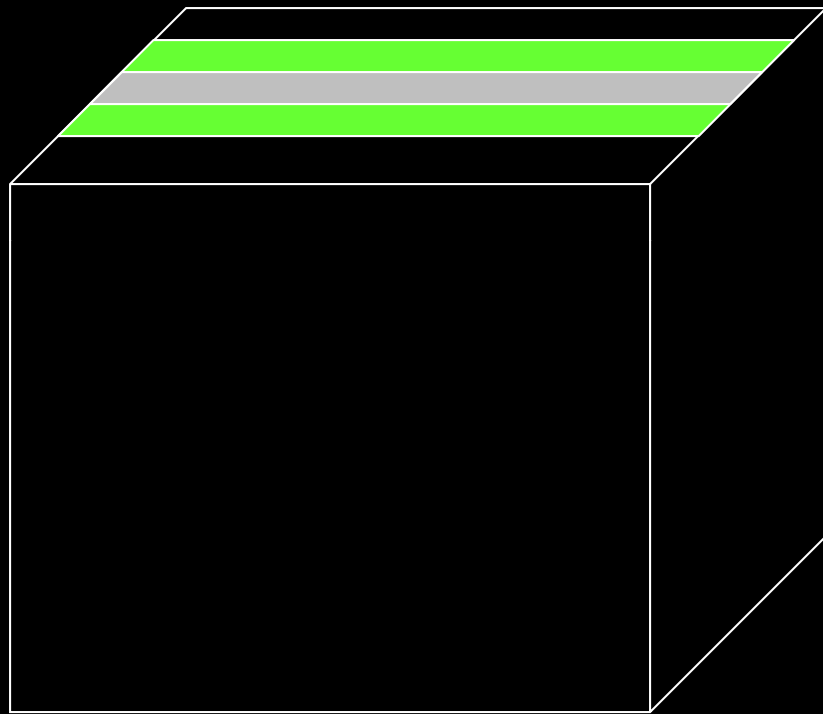

Activated

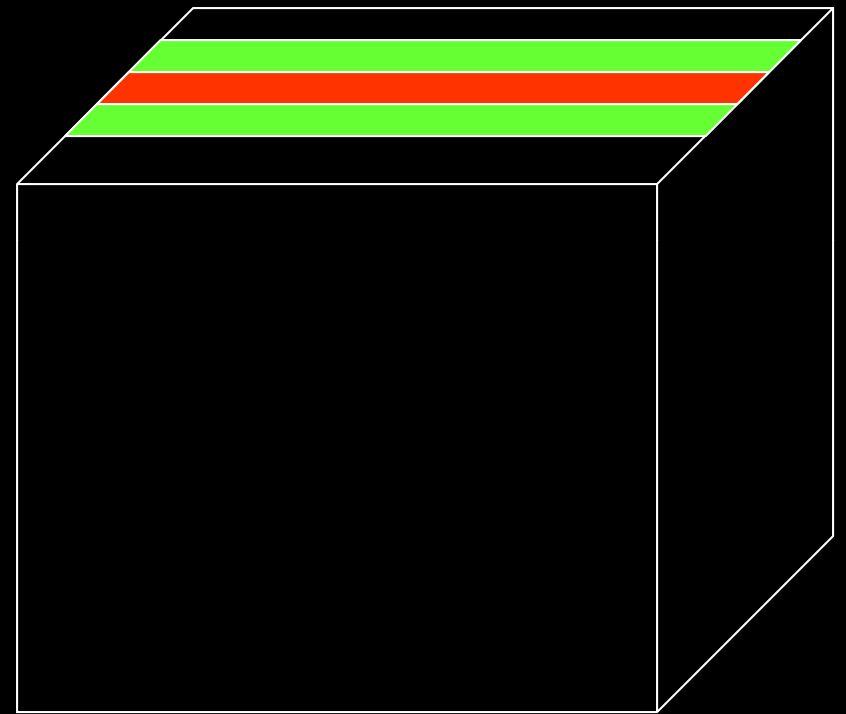
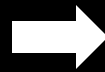

Expired

A NEW CLASS OF TTI

- It seals the box and also monitors shelf life
- The person opening the box will easily notice whether the perishables inside the box are of good quality or shelf life expired

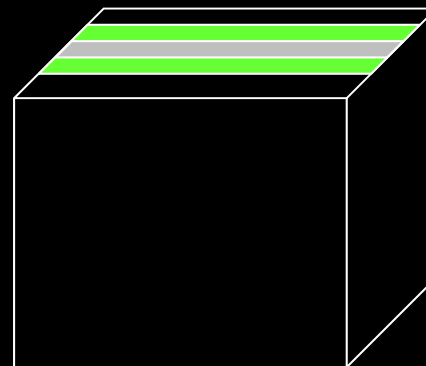
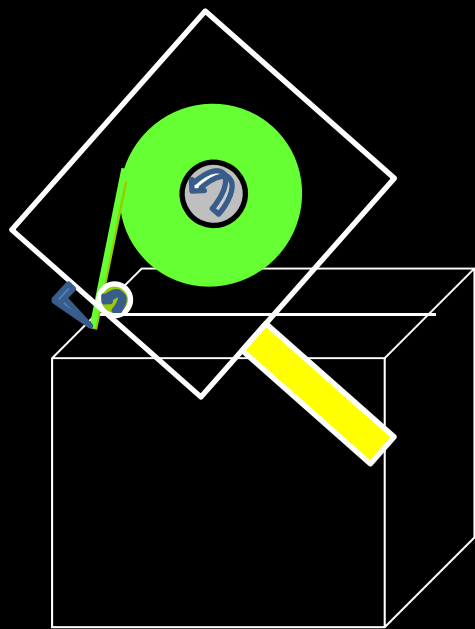

Activated

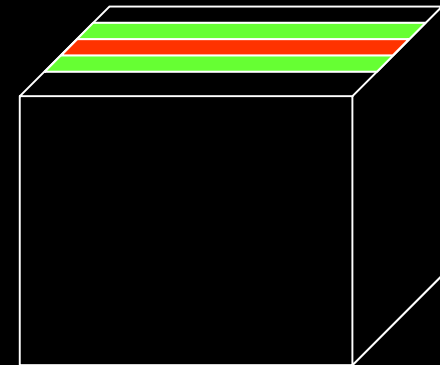

Expired

NANO-INDI PACKAGING TAPE TTI

A box sealed with Nano-TTI tape

[Click on image below for video](#)

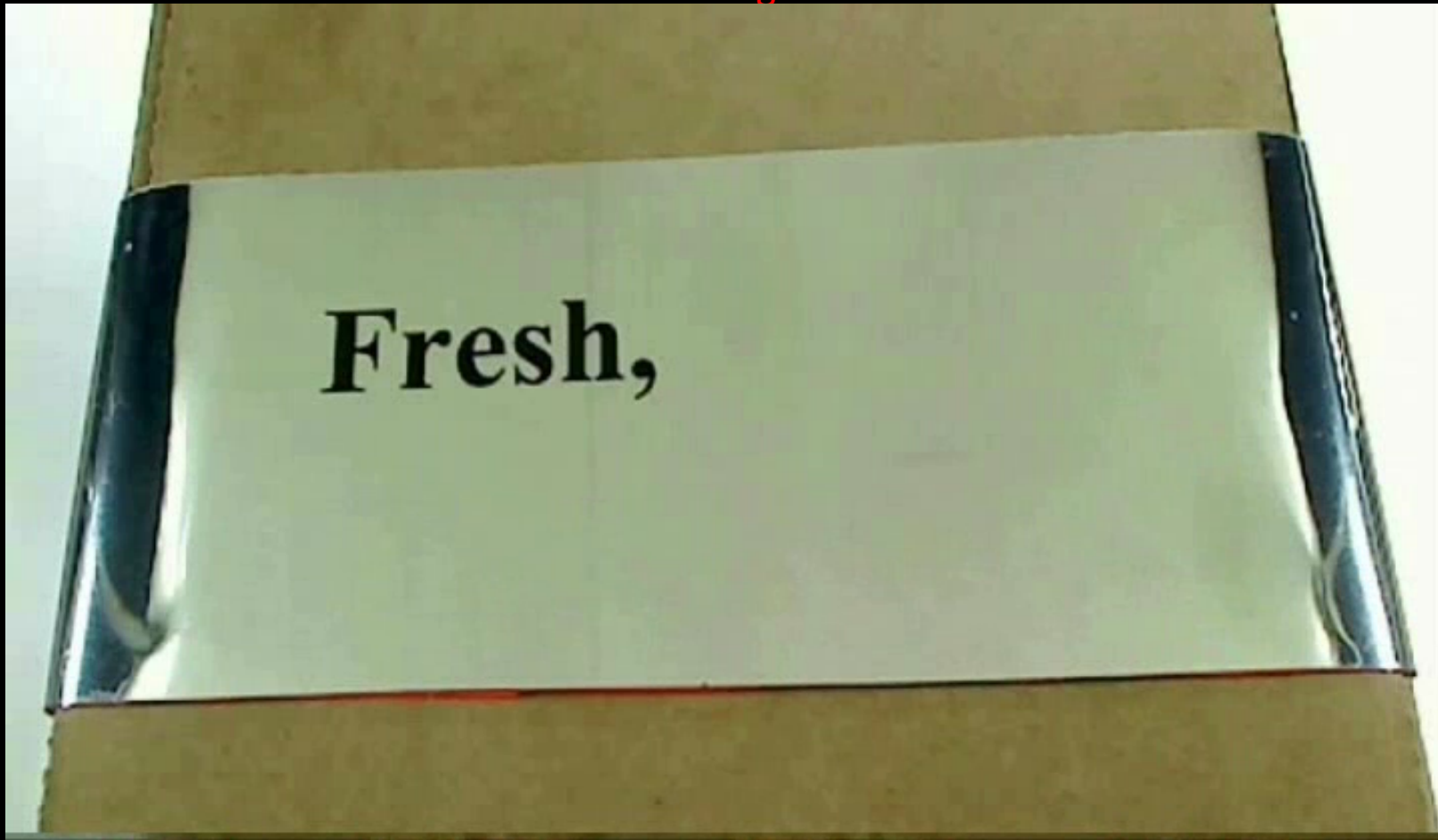

13 = 52 = 53 - 06

←Time

**WHY PACKAGING
TAPE TTI CAN BE
ACCEPTED BY THE
PERISHABLE
INDUSTRY?**

SEALING TAPE TTI

- Boxes/cartons are sealed with a tape
- No need for any special equipment for sealing boxes
- Use of TTI tape will not increase the cost to a level that perishable manufacturers/distributors will not use
- They would like to know the product is good quality before putting on the shelves
- Easy to train the shelf-loader rather than the consumers (there is no real training required as the TTI is self reading)

NANO-INDIS™

**A REVOLUTION IN
INDICATOR TECHNOLOGY**

**AN INDICATOR TECHNOLOGY WITH
A LONG INDUCTION PERIOD FOR
GO/NO-GO TYPE DEVICES**

NANO-CONVERSION TECHNOLOGY

AN IGNORED BUT NOVEL AND
UNIQUE FIELD OF NANOSCIENCE

FOR ADDITIONAL INFORMATION CONTACT:

Dr. Gordhan Patel, President

JP LABORATORIES, INC

120 Wood Avenue

Middlesex, NJ 08846

Phone: 732 469 6670

gnpatel@nanoconvertology.com

www.nanoconvertology.com

www.jplabs.com

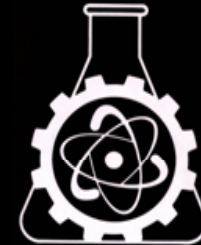

Nano-Conversion
Technology